

Engineering Requirements Unit (ERU)

Invites All the Students to Join

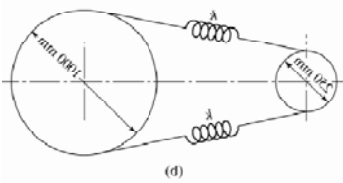

A Workshop in Applied Differential Equations

**Simulation and Modeling of Engineering Systems
with MATLAB -SIMULINK**

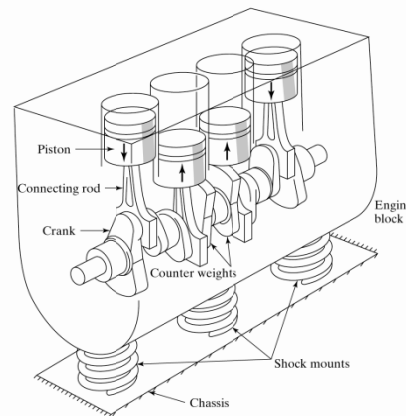
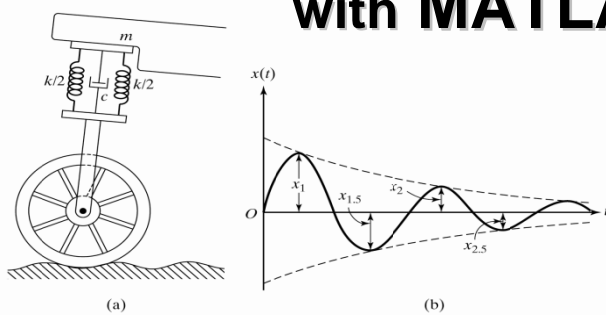

Workshop syllabus:

- **Simulation and Modeling of Engineering Systems.**
- **Using MATLAB-SIMULINK to solve Dynamic Systems.**

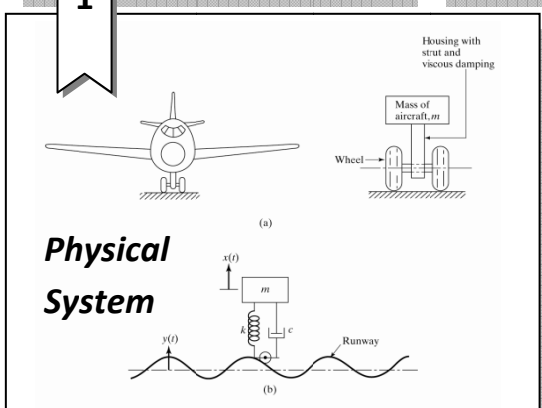
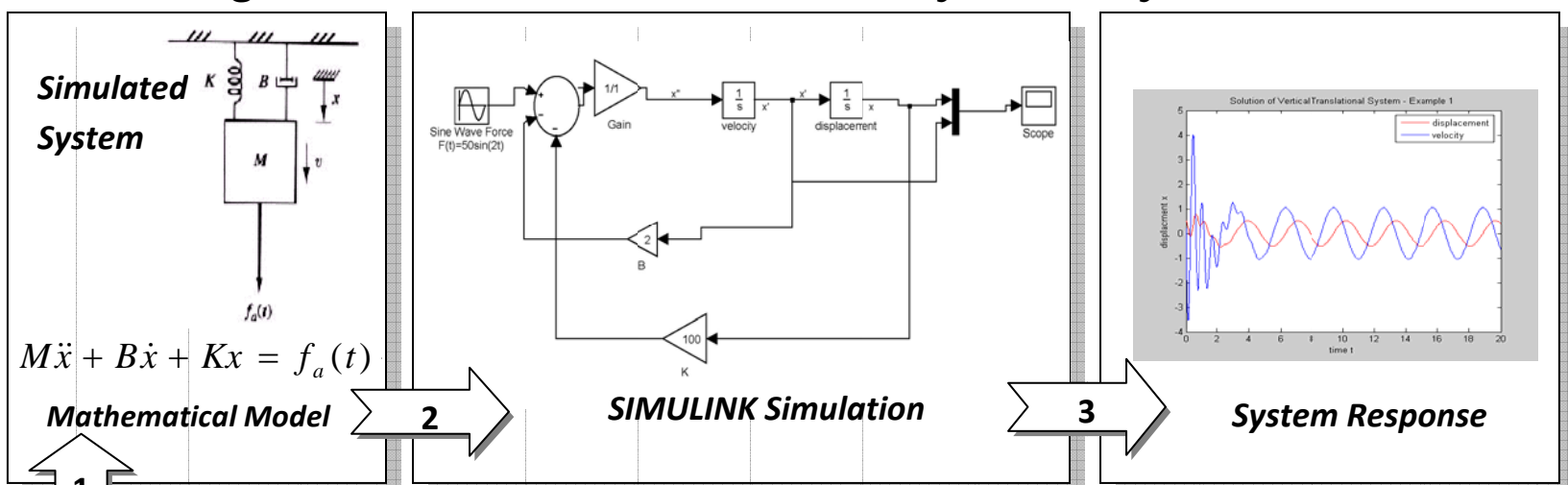

Location: Jimi 1Campus, B77 Room 12

Time: 11 am -1 pm

Date: May 20, 2010 (Thursday)